

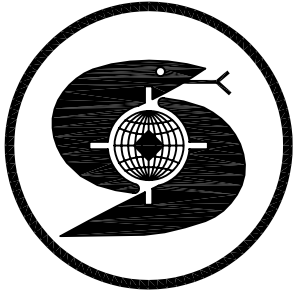

REVISIONS				
ZONE	REV	DESCRIPTION	DATE	APPROVED



PRICE

THESE PARTS ARE CLASSIFIED AS A MACHINE GUN, AND REQUIRE A ATF LICENSE TO OWN AND FABRICATE ATF IS NOT ISSUING LICENSE AT THIS TIME VIOLATION OF THIS LAW WILL GET YOU 10 YEAR IN A FEDERAL PRISON.

		 GWS CONSULTANT AND ENGINEERING SERVICES		
		(Sionics) SKS AUTOSEAR		
	SIZE A	FSCM NO.	DWG NO. GWS860-103	REV
	SCALE 2X			SHEET 1 OF 4



REVISIONS				
ZONE	REV	DESCRIPTION	DATE	APPROVED

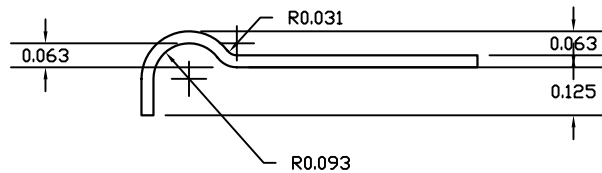
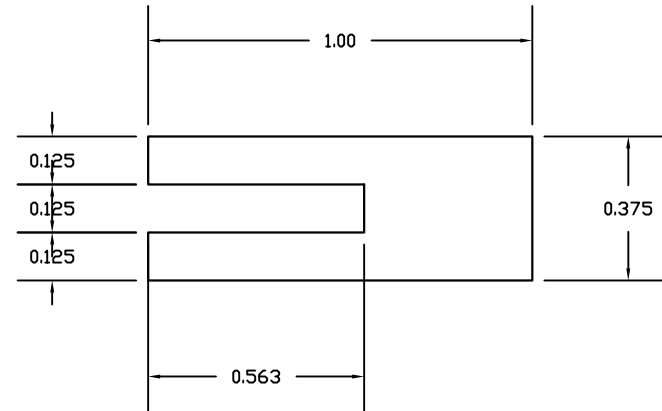
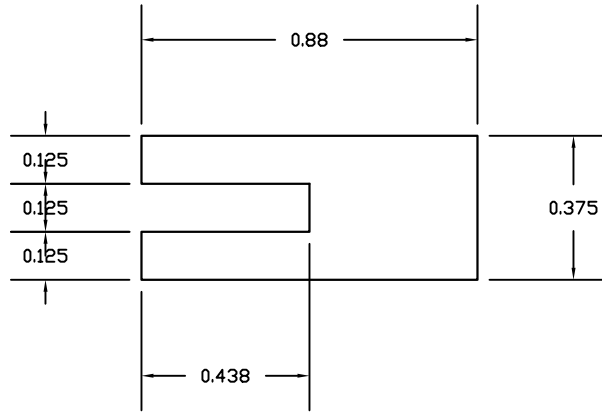

THESE PARTS ARE CLASSIFIED AS A MACHINE GUN, AND REQUIRE A AFT LICENSE TO OWN AND FABRICATE AFT IS NOT ISSUING LICENSE AT THIS TIME VIOLATION OF THIS LAW WILL GET YOU 10 YEAR IN A FEDERAL PRISON.

MATERIAL: 1/32, TOOL STEEL		 GWS CONSULTANT AND ENGINEERING SERVICES		
		(Sionics) SKS AUTOSEAR		
SIZE A	FSCM NO.	DWG NO. GWS860-103	REV	
SCALE 2X		SHEET 2 OF 4		



1. MAKE SURE THAT THE MAGAZINE AND RIFLE CHAMBER ARE EMPTY.
2. REMOVE THE TRIGGER ASSEMBLY UNIT FROM THE RIFLE BY PUTTING

THE SAFETY ON AND DEPRESSING THE CATCH BEHIND THE TRIGGER GUARD.

3. REMOVE THE MAGAZINE CATCH RETAINING PIN.
4. SLIDE OUT THE MAGAZINE CATCH AND SPRING.
5. REMOVE THE TRIGGER SPRING, DO NOT REPLACE.
6. SLIDE OUT THE SEAR.
7. SLIDE YOUR AUTO SEAR IN WITH THE FORKED END TOWARD THE TRIGGER. IT MUST SLIDE EASILY.
8. REPLACE THE FACTORY SEAR IN ITS ORIGINAL POSITION ABOVE THE AUTO SEAR.
9. REPLACE THE MAGAZINE CATCH AND SPRING.
10. REPLACE THE MAGAZINE CATCH RETAINING PIN.
11. REPLACE THE TRIGGER ASSEMBLY UNIT FROM THE RIFLE.
12. REMOVE THE RECEIVER COVER AND BOLT CARRIER SPRING.
13. PULL THE TRIGGER AND WHILE KEEPING IT DEPRESSED, MANUALLY MOVE THE BOLT CARRIER BACK AND FORTH. THE HAMMER SHOULD FALL EACH TIME UPON LOCKING OF THE BOLT. REMOVE FINGER FROM THE TRIGGER. MANUALLY MOVE THE BOLT CARRIER BACK AND FORTH. THE HAMMER SHOULD NOT FALL UPON LOCKING OF THE BOLT. WARNING ! IF THE HAMMER FALLS DO NOT ATTEMPT TO LOAD AND FIRE THE WEAPON. REMOVE THE AUTOSEAR AND REWORK IT UNTIL THE HAMMER DOES NOT FALL.
14. REPLACE THE BOLT CARRIER PRING AND RECEIVER COVER.
15. GO OUTSIDE, LOAD AND TEST FIRE THE WEAPON.
- 16 BE VERY CAREFUL!!! REMEMBER, ONCE THE AUTOSEAR IS IN PLACE, SIMPLY CHAMBERING A ROUND MAY CAUSE THE WEAPON TO FIRE A SINGLE ROUND OR A BURST OF SEVERAL ROUNDS. IF THE AUTOSEAR IS NOT QUITE RIGHT. ONCE THE AUTOSEAR HAS BEEN FILED AND SHAPED CORRECTLY, THER SHOULD BE NO PROBLEM.

REVISIONS				
ZONE	REV	DESCRIPTION	DATE	APPROVED

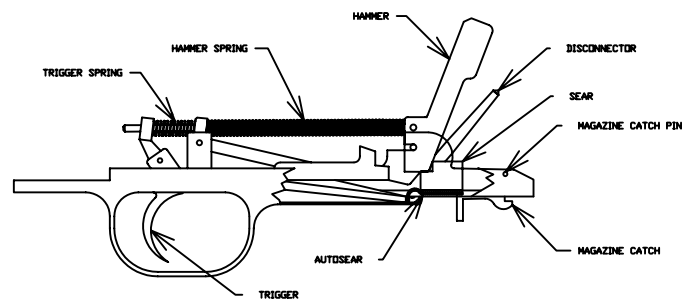

THESE PARTS ARE CLASSIFIED AS A MACHINE GUN, AND REQUIRE A AFT LICENSE TO OWN AND FABRICATE AFT IS NOT ISSUING LICENSE AT THIS TIME VIOLATION OF THIS LAW WILL GET YOU 10 YEAR IN A FEDERAL PRISON.

MATERIAL: 1/32, TOOL STEEL		 GWS CONSULTANT AND ENGINEERING SERVICES		
(Sionics) SKS AUTOSEAR				
SIZE A	FSCM NO.	DWG NO. GWS860-103	REV	
SCALE 2X		SHEET 3 OF 4		



REVISIONS				
ZONE	REV	DESCRIPTION	DATE	APPROVED

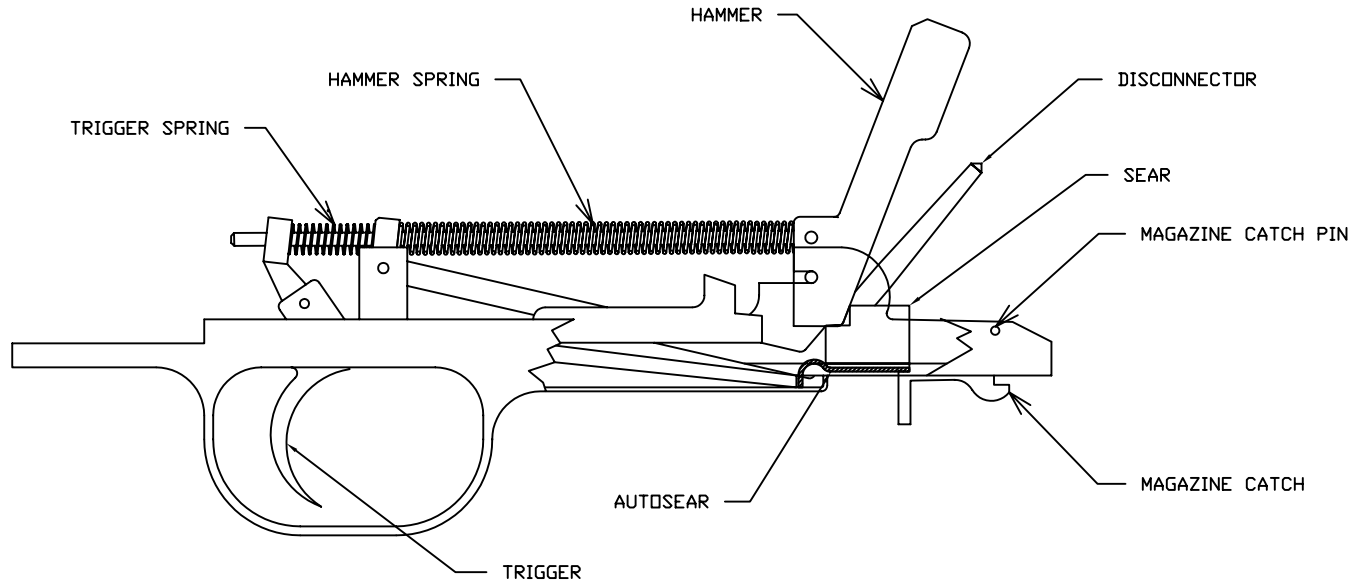

THESE PARTS ARE CLASSIFIED AS A MACHINE GUN, AND REQUIRE A ATF LICENSE TO OWN AND FABRICATE ATF IS NOT ISSUEING LICENSE AT THIS TIME VIOLATION OF THIS LAW WILL GET YOU 10 YEAR IN A FEDREAL PRISON.

MATERIAL: 1/32, TOOL STEEL		 GWS CONSULTANT AND ENGINEERING SERVICES		
(Sionics) SKS AUTOSEAR				
SIZE A	FSCM NO.	DWG NO. GWS860-103	REV	
SCALE 2X		SHEET 4 OF 4		